

Пластины для обработки железнодорожных колёс и рельсов

Для токарной обработки

BNUX

266

LN..X

266

RCMX, ROUX

267

RCMM, RPUX

268

Для фрезерной обработки

RNUX

269

LNUX

269

SNEX

270

Для сверления рельсов

WCMX

271

Марки твёрдых сплавов для ж/д пластин

272

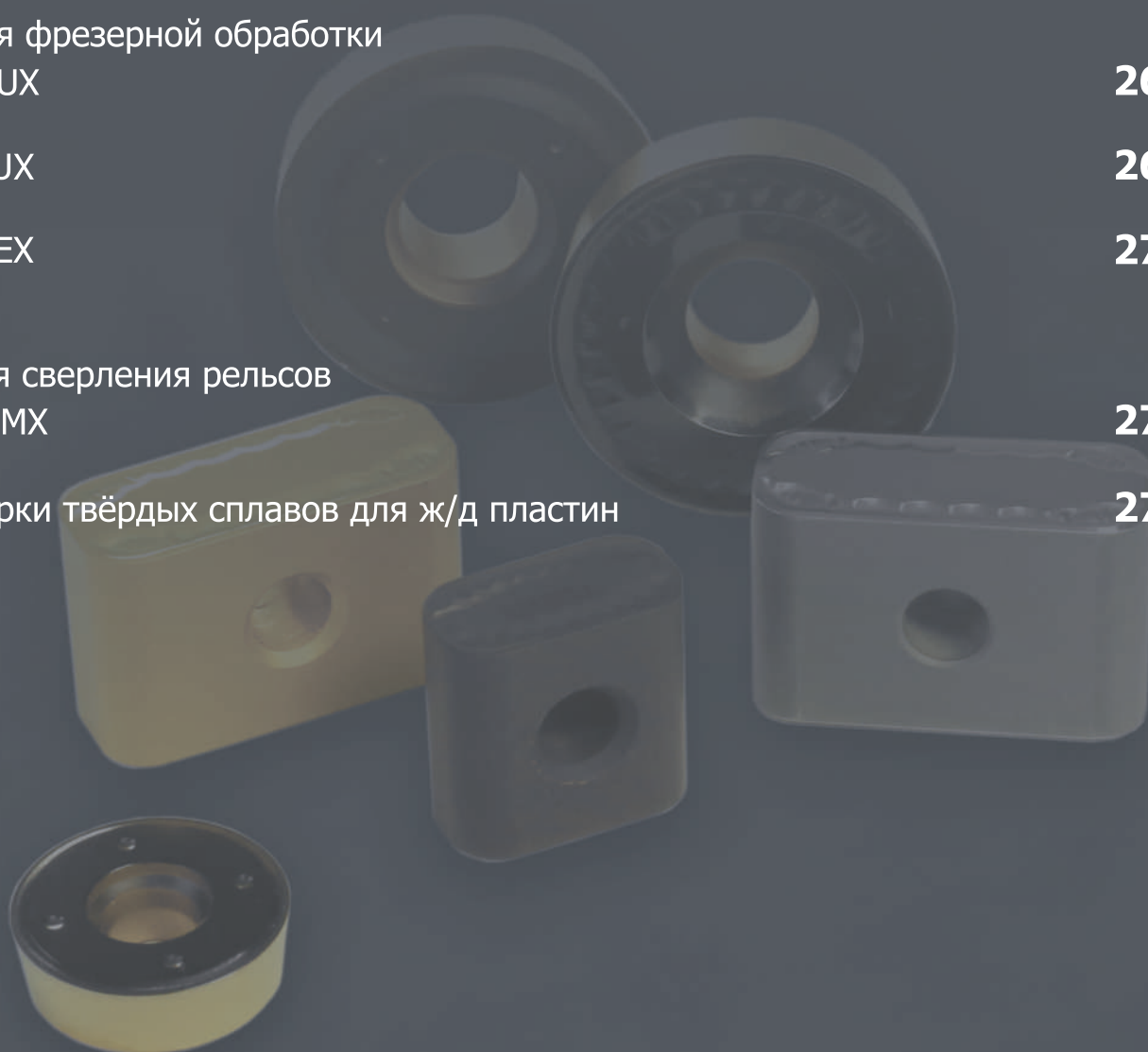



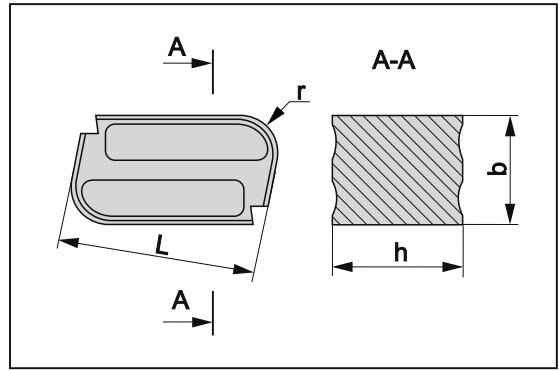

| BNUX | | | | | |
|------------------|----|----|----|--|--|
| Размеры пластины | L | h | b | | |
| 2015 | 22 | 15 | 12 | | |
| | | | | | |
| | | | | | |
| | | | | | |
| | | | | | |
| | | | | | |

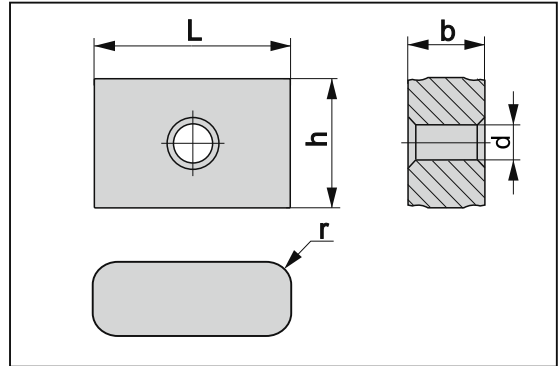

| Форма | Обозначение ISO | KC35 | KC35PT | MC221 | TC20PT-P | T14K8 | | | | | | | | | | | r мм | | | | |
|---|-----------------|------|--------|-------|----------|-------|--|--|--|--|--|--|--|--|--|--|------|--|--|-----|--|
| | | | | | | | | | | | | | | | | | | | | | |
|  | BNUX-201540 TN | ● | + | | | | | | | | | | | | | | | | | 4,0 | |
| | | | | | | | | | | | | | | | | | | | | | |
| | | | | | | | | | | | | | | | | | | | | | |
| | | | | | | | | | | | | | | | | | | | | | |
| | | | | | | | | | | | | | | | | | | | | | |
| | | | | | | | | | | | | | | | | | | | | | |
| | | | | | | | | | | | | | | | | | | | | | |
| | | | | | | | | | | | | | | | | | | | | | |

| LN..X | | | | | |
|------------------|----|----|----|-----|--|
| Размеры пластины | L | h | b | d | |
| 1919 | 19 | 19 | 10 | 6,4 | |
| 3019 | 30 | 19 | 12 | 6,4 | |
| | | | | | |
| | | | | | |
| | | | | | |
| | | | | | |



| Форма | Обозначение ISO | KC35 | KC35PT | MC221 | TC20PT-P | T14K8 | | | | | | | | | | | r мм | | | |
|---|------------------|------|--------|-------|----------|-------|--|--|--|--|--|--|--|--|--|--|------|--|--|-----|
| | | | | | | | | | | | | | | | | | | | | |
|  | LNMX-191940 PR | + | ● | ● | | | | | | | | | | | | | | | | 4,0 |
| | | | | | | | | | | | | | | | | | | | | |
|  | LNUX-191940-220 | + | ● | ● | | | | | | | | | | | | | | | | 4,0 |
| | | | | | | | | | | | | | | | | | | | | |
|  | LNUX-301940 TN02 | + | ● | ● | | | | | | | | | | | | | | | | 4,0 |
| | | | | | | | | | | | | | | | | | | | | |

+ - Изготовление после согласования объема
 ● - Наличие на складе

RNUX

| Размеры пластины | L | D | d ₁ | h |
|------------------|----|---|----------------|----|
| 1212 | 12 | 7 | 4,4 | 12 |
| | | | | |
| | | | | |
| | | | | |
| | | | | |
| | | | | |
| | | | | |
| | | | | |

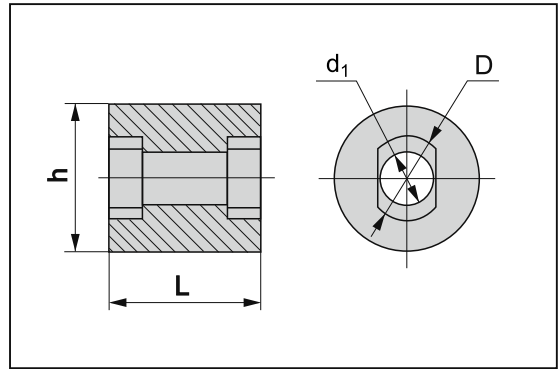

| Форма | Обозначение ISO | KC25 | KC35 | T14K8 | TC35EM | TP35DM | | | | | | | | | | | | r | | |
|-------|-----------------|------|------|-------|--------|--------|--|--|--|--|--|--|--|--|--|--|--|----|---|--|
| | | | | | | | | | | | | | | | | | | мм | | |
| | RNUX-1212MO TN | + | | ● | | | | | | | | | | | | | | | - | |
| | | | | | | | | | | | | | | | | | | | | |
| | | | | | | | | | | | | | | | | | | | | |
| | | | | | | | | | | | | | | | | | | | | |
| | | | | | | | | | | | | | | | | | | | | |
| | | | | | | | | | | | | | | | | | | | | |
| | | | | | | | | | | | | | | | | | | | | |
| | | | | | | | | | | | | | | | | | | | | |
| | | | | | | | | | | | | | | | | | | | | |
| | | | | | | | | | | | | | | | | | | | | |

LNUX

| Размеры пластины | L | h | b | d |
|------------------|----|----|----|-----|
| 3019 | 30 | 19 | 12 | 6,4 |
| | | | | |
| | | | | |
| | | | | |
| | | | | |
| | | | | |
| | | | | |
| | | | | |
| | | | | |

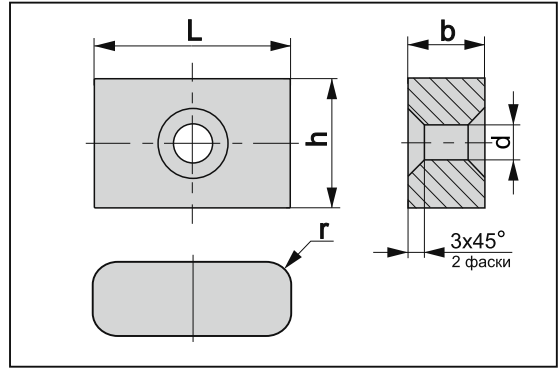







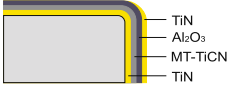

| Форма | Обозначение ISO | KC25 | KC35 | T14K8 | TC35EM | TP35DM | | | | | | | | | | | | r | | |
|-------|--------------------|------|------|-------|--------|--------|--|--|--|--|--|--|--|--|--|--|--|----|-----|--|
| | | | | | | | | | | | | | | | | | | мм | | |
| | LNUX-301940 TN02-P | | | ● | | | | | | | | | | | | | | | 4,0 | |
| | | | | | | | | | | | | | | | | | | | | |
| | | | | | | | | | | | | | | | | | | | | |
| | | | | | | | | | | | | | | | | | | | | |
| | | | | | | | | | | | | | | | | | | | | |
| | | | | | | | | | | | | | | | | | | | | |
| | | | | | | | | | | | | | | | | | | | | |
| | | | | | | | | | | | | | | | | | | | | |
| | | | | | | | | | | | | | | | | | | | | |
| | | | | | | | | | | | | | | | | | | | | |

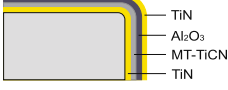
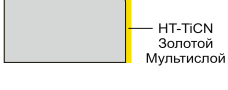
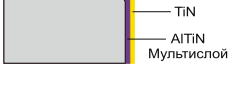
+ - Изготовление после согласования объема
 ● - Наличие на складе

Пластины для обработки ж/д колес и рельсов
 Дополнительная информация

Марки сплавов для ж/д пластин

| Сплав | | Описание | Область применения | | | | | | | | | | | | | | | | |
|--------------|--|--|--------------------|---|---|---|---|---|----|----|----|----|----|----|----|----|----|--|--|
| Наименование | Вид покрытия | | P | M | K | N | S | H | 05 | 10 | 15 | 20 | 25 | 30 | 35 | 40 | 45 | | |
| TC20PT-P |  | Чистовая и получистовая обработка углеродистых при средней и высокой скорости резания, высокая износостойкость. В сочетании с прочными геометриями хорошо сопротивляется износу. | P | | | | | | | | | | | | | | | | |
| | | | M | | | | | | | | | | | | | | | | |
| | | | K | | | | | | | | | | | | | | | | |
| | | | N | | | | | | | | | | | | | | | | |
| | | | S | | | | | | | | | | | | | | | | |
| | | | H | | | | | | | | | | | | | | | | |
| TP20AM |  | Износостойкий среднезернистый сплав с легированной основой и мультислойным PVD покрытием. Первый выбор для лёгкой обработки материалов группы P. | P | | | | | | | | | | | | | | | | |
| | | | M | | | | | | | | | | | | | | | | |
| | | | K | | | | | | | | | | | | | | | | |
| | | | N | | | | | | | | | | | | | | | | |
| | | | S | | | | | | | | | | | | | | | | |
| | | | H | | | | | | | | | | | | | | | | |
| KC35PT |  | Среднезернистый легированный сплав для обработки колёсных пар. Износостойкая основа в сочетании с толстым CVD покрытием. | P | | | | | | | | | | | | | | | | |
| | | | M | | | | | | | | | | | | | | | | |
| | | | K | | | | | | | | | | | | | | | | |
| | | | N | | | | | | | | | | | | | | | | |
| | | | S | | | | | | | | | | | | | | | | |
| | | | H | | | | | | | | | | | | | | | | |
| TC35EM |  | Среднезернистый легированный сплав для фрезерования углеродистых и легированных сталей. В сочетании с прочной геометрией обеспечивает хорошую стойкость при ударных нагрузках. | P | | | | | | | | | | | | | | | | |
| | | | M | | | | | | | | | | | | | | | | |
| | | | K | | | | | | | | | | | | | | | | |
| | | | N | | | | | | | | | | | | | | | | |
| | | | S | | | | | | | | | | | | | | | | |
| | | | H | | | | | | | | | | | | | | | | |
| TP35DM |  | Износостойкий сплав для фрезерования рельсов. Хорошая индикация износа по задней поверхности. | P | | | | | | | | | | | | | | | | |
| | | | M | | | | | | | | | | | | | | | | |
| | | | K | | | | | | | | | | | | | | | | |
| | | | N | | | | | | | | | | | | | | | | |
| | | | S | | | | | | | | | | | | | | | | |
| | | | H | | | | | | | | | | | | | | | | |
| TC40EM |  | Сплав с прочной основой для сверления отверстий в рельсах при не стабильных условиях резания. | P | | | | | | | | | | | | | | | | |
| | | | M | | | | | | | | | | | | | | | | |
| | | | K | | | | | | | | | | | | | | | | |
| | | | N | | | | | | | | | | | | | | | | |
| | | | S | | | | | | | | | | | | | | | | |
| | | | H | | | | | | | | | | | | | | | | |
| KC25 | Среднезернистый (TK)  | Среднезернистый сплав без износостойкого покрытия для обработки углеродистых и легированных сталей. | P | | | | | | | | | | | | | | | | |
| | | | M | | | | | | | | | | | | | | | | |
| | | | K | | | | | | | | | | | | | | | | |
| | | | N | | | | | | | | | | | | | | | | |
| | | | S | | | | | | | | | | | | | | | | |
| | | | H | | | | | | | | | | | | | | | | |
| KC35 | Среднезернистый (ТТК)  | Среднезернистый износостойкий сплав без покрытия для получистовой и лёгкой черновой обработки легированных сталей на низких и средних скоростях резания. | P | | | | | | | | | | | | | | | | |
| | | | M | | | | | | | | | | | | | | | | |
| | | | K | | | | | | | | | | | | | | | | |
| | | | N | | | | | | | | | | | | | | | | |
| | | | S | | | | | | | | | | | | | | | | |
| | | | H | | | | | | | | | | | | | | | | |
| MC221 | Среднезернистый (ТТК)  | Среднезернистый легированный износостойкий сплав без покрытия для чистовой обработки легированных сталей на низких и средних скоростях резания. | P | | | | | | | | | | | | | | | | |
| | | | M | | | | | | | | | | | | | | | | |
| | | | K | | | | | | | | | | | | | | | | |
| | | | N | | | | | | | | | | | | | | | | |
| | | | S | | | | | | | | | | | | | | | | |
| | | | H | | | | | | | | | | | | | | | | |
| T14K8 | Среднезернистый (TK)  | Сплав для получистового и чернового фрезерования углеродистых и легированных сталей. | P | | | | | | | | | | | | | | | | |
| | | | M | | | | | | | | | | | | | | | | |
| | | | K | | | | | | | | | | | | | | | | |
| | | | N | | | | | | | | | | | | | | | | |
| | | | S | | | | | | | | | | | | | | | | |
| | | | H | | | | | | | | | | | | | | | | |

